

Power

ActiveFactory software, FactorySuite,
Wonderware Historian

Kola Nuclear Power Plant

Wonderware Historian collects and ActiveFactory software analyzes data in Nuclear Power Plants

by Klinkmann CIS, Russia

“This concept will allow Rosenergoatom to create a centralized database for decision making support system covering all its plants.”

Victor Antufyev, Head of Department, Kola Nuclear Power Plant



Company Overview

Kola Nuclear Power Plant – Murmansk Region, Russia
The Kola Nuclear Power Plant is a part of Rosenergoatom, one of the largest power producers and distributors of the ten biggest Russian nuclear power plants. Kola Nuclear Plant is the basic supplier of electric power for the large regions located in northwest of Russia. At the station there are four power units running with a total capacity of 1760 MWe, that makes more than 50% of capacity of power supply system of all Kola Peninsula. The plant can develop more than 12 billion watt-hours of the electric power per year.

Safety is the Highest Priority

Rosenergoatom directs its main efforts and resources on providing safety at all life cycle phases of nuclear power plants. To realize this task in 2003-2005 Rosenergoatom made wide evaluations to specify optimal data collecting and analyzing system for technological parameters in its Nuclear Power Plants. Based on these evaluations, in 2005, a data processing project was completed at Kolskaya Nuclear Power Plant (Kola NPP).

The project was focused on developing a data collecting and analyzing system to manage radiation deviation monitoring in Nuclear Power Plant's power unit. The Data Collection and Transfer System (DCTS) is based on Wonderware Historian's (formerly known as IndustrialSQL or InSQL) industrial database and ActiveFactory software data analyzing and reporting tools.

For the DCTS following performance requirements were set:

- long lasting and trouble free operation;
- collecting of analogue and discrete data values in real time;
- long lasting historical data storage; fast and flexible data access for analysis and reporting;
- easy integration into various automation, measuring and IT systems;
- once created, easy to copy and implement into various plants.

Wonderware offers optimal solution

Old existing system was not robust and had not sufficient efficiency. There was a problem with administration and management of database parameters (adding of the new one, deleting, modification of characteristics and attributes. The reason was in non relation model of this database). Also there were not deep retrospective of trends with sufficient accuracy and archive for emergency investigations. So there was high expenditure of investigations.

After a careful evaluation of different available alternatives, Wonderware Historian industrial database with ActiveFactory software reporting tools was specified by Rosenergoatom for the DCTS system. High speed in data collecting, effective storing of data, flexible SQL queries and availability of large amount of ready input-output interface servers, were all

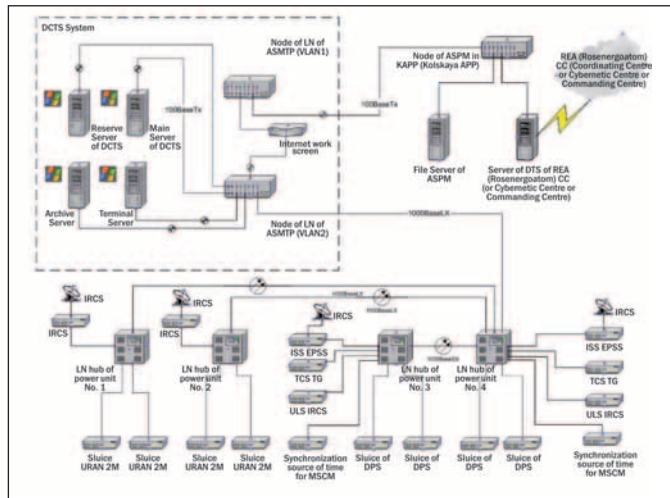

Functional schema of DCTS system

important factors when choosing Wonderware Historian.

The Data Collection and Transfer System (DCTS) consists of a distributed network with various data collecting devices from subsystems of power units, such as:

- data processing system (DPS);
- intra reactor control system (IRCS);
- informational supply system for emergency power supply system (ISS EPSS);
- automation and power unit shield systems (AUPL – automation of unloading and power limiting), automation of power control, ANFC automation of neuronal flow control and others;
- diesel generator automatic control systems (DG ACS);
- radiation safety automatic control systems (RSAC);
- radiation environment automatic control systems (REACS).

The DCTS system's database handles and contains some 10.000 analogue and 9.000 discrete parameters and tens of events tags for automatic data collection for other information systems. As a result, the most complete and long-lasting technological data storage system on APP was created.

The whole project was realized by technical-engineering staff of Kola NPP with consulting support provided by Klinkmann, Wonderware distributor company.

There were three stages of achievement. The first stage included research and development, preliminary data obtaining, and making of technical requirements specification (3 months).

The next stage included system design, and export data to Wonderware Historian, I/O server adjustments and developments (4-5 months).

The last stage included electronic equipment and software purchase, hardware mounting, software installation, data acquisition start, validation and verification of parameters in Wonderware Historian storage, client software installation, training, and testing (6 months).

Fast and effective data collecting, analyzing, and reporting

Data collection system is built as a local network based on third generation 1 Gb/s Ethernet switchboard in which the block networks are integrated. Information flows, that are transferred from block networks by TCP/IP protocol by means of sluices and servers of upper level, come to two data collecting servers and are transformed into special data formats for further transfer and processing. Data receiving on archive server is carried out by means of special program switchboard similar to those installed on data collecting servers.

Wonderware SuiteLink interface servers are used mainly to transfer data from various devices into IDAS Wonderware Historian. Data updating in topics of analogue and state discrete parameters is made with a frequency of 1 to 20 seconds depending on type of data sources information systems. Event data about snapping into action of discrete sensors is processed separately and is transferred into Wonderware Historian archive through MDAS previously being recorded into buffer in order to avoid data losses.

Sensors snapping into action time markers are transferred from gear of OCD (Object Communication Device) together with information about current and previous discrete sensors' state. Thus "specification" of discrete sensors' state in archive is carried out. Registration of analogue parameters is carried out both in continuous stable state 'cyclically' and in alternation by 'aperture'. In alternation usually parameters of protection systems and automatic controls are registered, because in continuous state these parameters of power unit almost are not changing.

Some parameters are transferred to archive server by means of input-output server of OPC Link. Others are collected through MDAS from linked SQL servers by means of implementation by SQL the inquiries to Events tag. Current time in lower level systems and OCD is strictly synchronized with upper level systems' time. In



Fragment of Kola NPP equipment

Power

ActiveFactory software, FactorySuite, Wonderware Historian

systems where the accuracy of time synchronization should be not worse than 1 ms information about current time is transferred through field net based on RS 485 directly from UTS (Universal Time Systems). In systems where the accuracy of time synchronization should be less than 500 ms and/or more information about current time is transferred through directly from upper level servers by NTP protocol.

Presentation of archive information is carried out by means of software included in set of Wonderware ActiveFactory software, which gives to users flexible tools for any analysis and reporting.

Achievements

The implementation of Wonderware Historian allowed high-speed data actualization and data view and representation easier. Also it reduced an emergency investigation time, lowered the total cost of ownership for the system. Kola NPP has got a heterogenic information space of technology parameters completely

abstracted from hardware I/O system level. Also the Wonderware Historian became a good platform for calculations and diagnostics.

Now the Kola NPP is one of the best on parameters of steady work and a production efficiency among nuclear plants of Russia. Its achievements are confirmed by many awards, and in 2006 the Kola nuclear power plant is recognized as the best in the field of safety. The intention of Rosenergoatom is to implement the Wonderware software based DCTS system into corporation's various Nuclear Power Plants to allow standardized data collecting and reporting and to unify access to archive information sources and to simplify the integration of technological systems with production management systems (ERP) in various objects.

*This document was realized thanks to the support of:
Chief engineer V. Omelchuk, Head of Department V. Antufyev and
Engineer-Programmer D. Kuznetsov of Rosenergoatom*